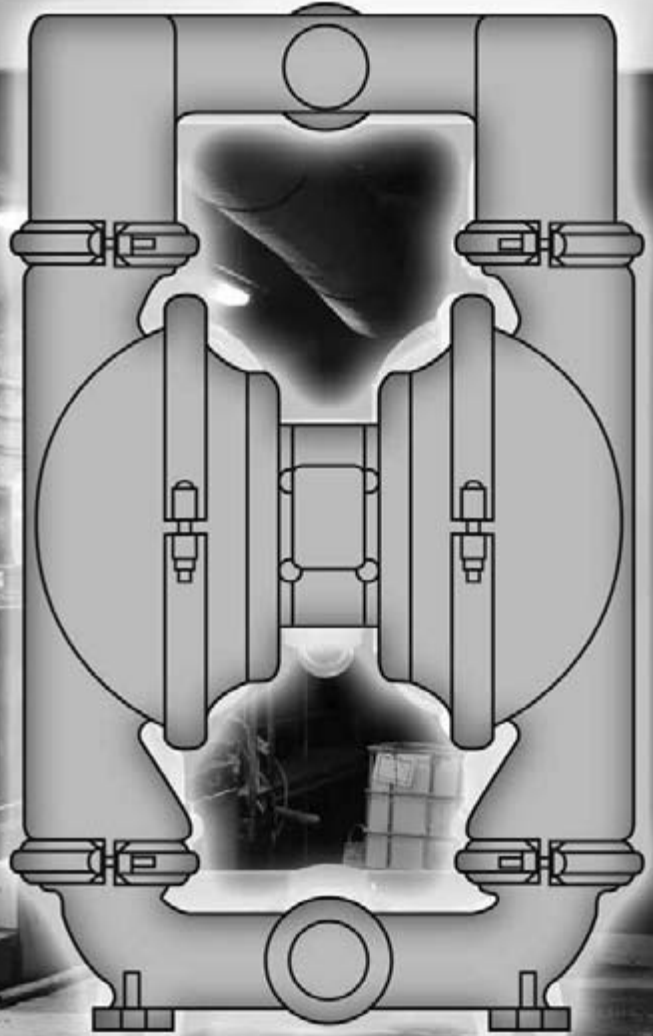




# NOMAD™

## OPERATION MANUAL

### NTG50 NOMAD TRANS-FLO™



AIR-OPERATED  DOUBLE DIAPHRAGM  PUMPS

**ALUMINUM Models**

**316 S.S. Models**



A JDA Global Company

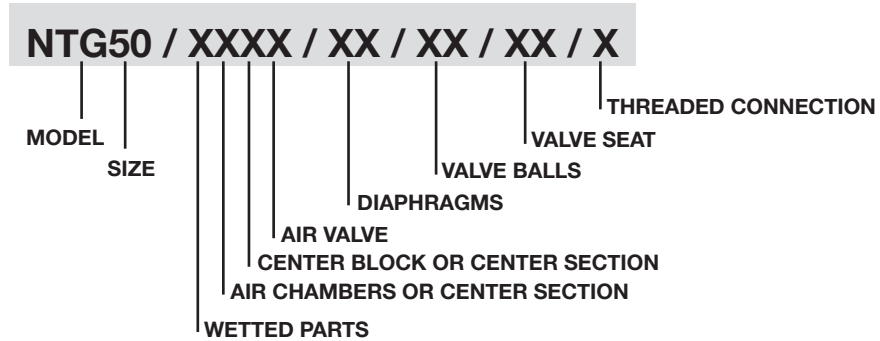
**CAUTION – SAFETY POINTS**

<b>TEMPERATURE LIMITS:</b>		
Neoprene	-17.8°C to 93.3°C	0°F to 200°F
Buna-N	-12.2°C to 82.2°C	10°F to 180°F
EPDM	-51.1°C to 137.8°C	-60°F to 280°F
Viton®	-40°C to 176.7°C	-40°F to 350°F
Santoprene®	-40°C to 107.2°C	-40°F to 225°F
Polyurethane	12.2°C to 65.6°C	10°F to 150°F
Hytrel®	-28.9°C to 104.4°C	-20°F to 220°F
PTFE	4.4°C to 104.4°C	40°F to 220°F

- 1.** Review the NOMAD Chemical Field Guide for all applications. The information provided is the “best thinking available” regarding chemical compatibility. The guide however, does not provide a recommendation.
- 2.** Always wear safety glasses during pump operation. A diaphragm rupture may force liquid to exit via air exhaust.
- 3.** When handling flammable fluids, prevent static sparking by properly grounding the pump.
- 4.** Do not exceed 125 psig (8.6 bar).
- 5.** Prior to maintenance, compressed air line should be disconnected to allow air pressure to bleed from pump.
- 6.** Tighten all clamp bands and hardware parts prior to installation. Fittings may loosen during transportation.

## PUMP DESIGNATION SYSTEM

**51 mm (2") Pump**  
**Maximum Flow Rate:**  
**617 lpm (163 gpm)**



## MATERIAL CODES

### MODEL

NTG50 = 51MM (2")

### WETTED PARTS & OUTER PISTON

AA = ALUMINUM / ALUMINUM  
 S = 316 S.S.

### AIR CHAMBERS

A = ALUMINUM

### CENTER BLOCK

A = ALUMINUM

### AIR VALVE

B = BRASS

### DIAPHRAGMS

BN = BUNA-N (Red Dot)  
 FG = HYTREL  
 ND = EPDM (Blue Dot)  
 NE = NEOPRENE (Green Dot)  
 SN = SANTOPRENE  
 TF = PTFE  
 VT = VITON (White Dot)

### VALVE BALL

BN = BUNA-N (Red Dot)  
 FG = HYTREL  
 ND = EPDM (Blue Dot)  
 NE = NEOPRENE (Green Dot)  
 SN = SANTOPRENE  
 TF = PTFE (White)  
 VT = VITON (White Dot)

### VALVE SEAT

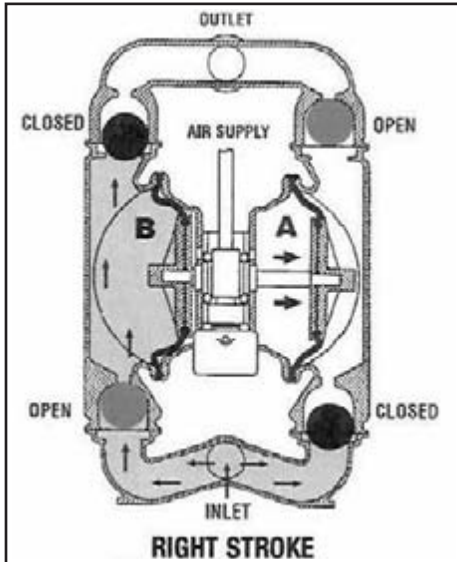
A = ALUMINUM\*  
 BN = BUNA-N (Red Dot)  
 FG = HYTREL  
 ND = EPDM (Blue Dot)  
 NE = NEOPRENE (Green Dot)  
 S = STAINLESS\*  
 SN = SANTOPRENE  
 VT = VITON

\*Valve seat o-ring required.

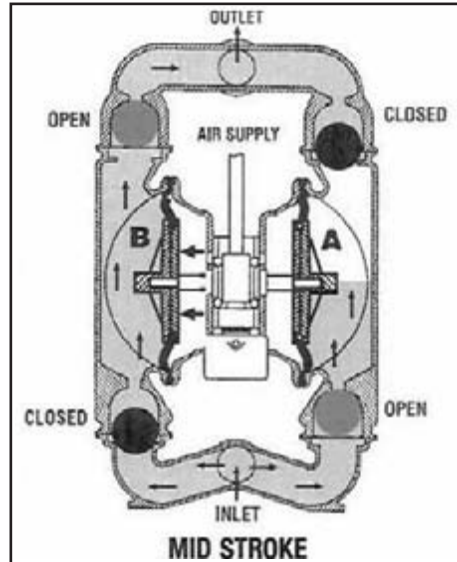
### VALVE SEAT O-RING

TF = PTFE (White)

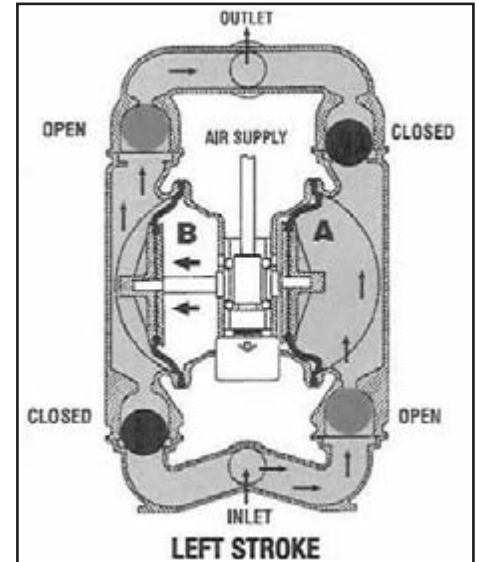
## AIR OPERATED DOUBLE DIAPHRAGM PUMPS FUNCTIONALITY AND FLOW PATTERN



**Figure 1:** Air valve directs pressurized air to the back side of diaphragm A. Compressed air is applied directly to the liquid column separated by elastomeric diaphragms. The diaphragm acts as a separation membrane between the compressed air and liquid, balancing the load and removing mechanical stress from the diaphragm. The opposite diaphragm is pulled in by the shaft connected to the pressurized diaphragm. Diaphragm B is on its suction stroke; air behind the diaphragm has been forced out to the atmosphere through the exhaust port of the pump. Atmospheric pressure forces fluid into the inlet manifold forcing the inlet valve ball off its seat. Liquid is free to move past the inlet valve ball and fill the liquid chamber (see shaded area).

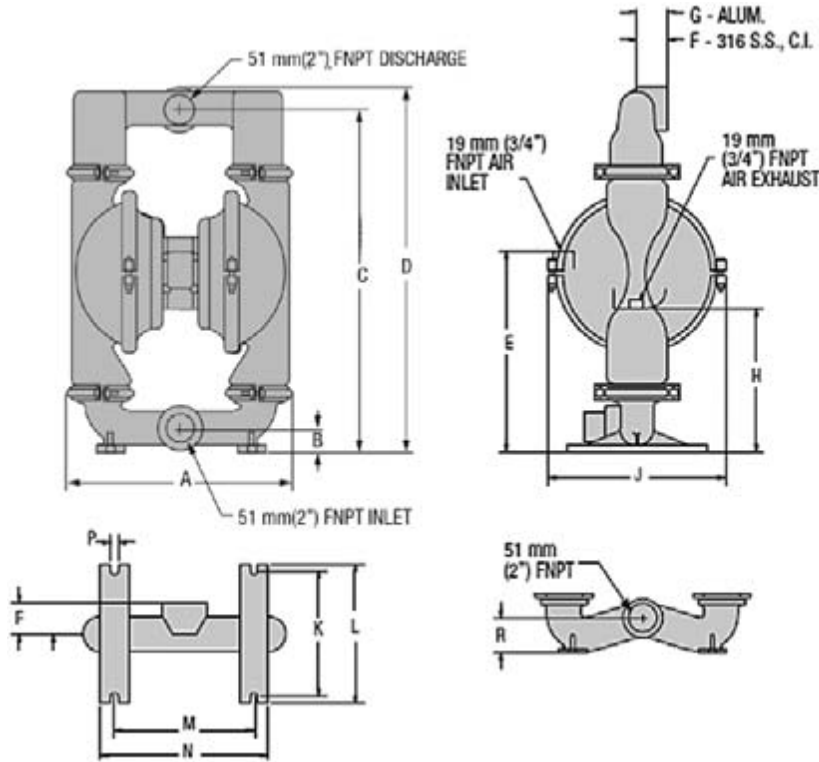


**Figure 2:** When the pressurized diaphragm, diaphragm A, reaches the limit of its discharge stroke, the air valve redirects pressurized air to the back side of the diaphragm B. The pressurized air forces diaphragm B away from the center block while pulling diaphragm A to the center block. Diaphragm B is now on its discharge stroke. These same hydraulic forces lift the discharge valve ball off its seat, while the opposite discharge valve ball is forced onto its seat, forcing fluid to flow through the pump discharge. Atmospheric pressure forces fluid into the inlet manifold of the pump. The inlet valve ball is forced off its seat allowing the fluid being pumped to fill the liquid chamber.



**Figure 3:** At completion of the stroke, the air valve again redirects air to the back side of diaphragm A, which starts diaphragm B on its exhaust stroke. As the pump reaches its original starting point, each diaphragm has gone through one exhaust and one discharge stroke. This constitutes one complete pumping cycle. The pump may take several cycles to completely prime depending on the conditions of the application.

## DIMENSIONAL DRAWINGS



## DIMENSIONS

ITEM	METRIC (mm)	STANDARD (inch)
A	404	15.9
B	48	1.9
C	630	24.8
D	668	26.3
E	361	14.2
F	58	2.3
G	61	2.4
H	272	10.7
J	343	13.5
K	229	9.0
L	254	10.0
M	257	10.1
N	312	12.3
P	15	0.6
R	64	2.5

BSP threads available.

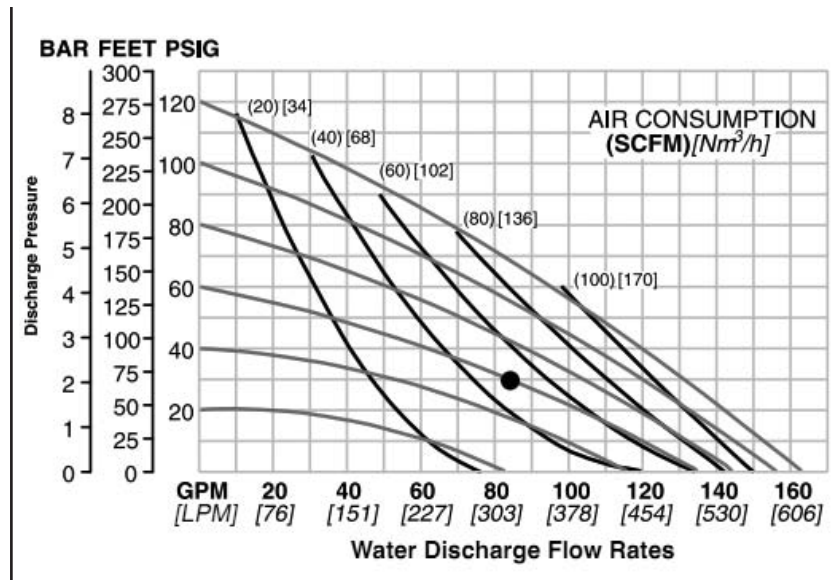
## PERFORMANCE NTG50 METAL RUBBER-FITTED

Height.....	668 mm (26.3")
Width.....	404 mm (15.9")
Depth.....	343 mm (13.5")
Est. Ship Weight.....	Aluminum 33 kg (72 lbs) 316 S.S. 51 kg (112 lbs)
Air Inlet.....	19 mm (3/4")
Inlet.....	51 mm (2")
Outlet.....	51 mm (2")
Suction Lift.....	6.4 m Dry (21') 9.5 m Wet (31')
Displacement/Stroke.....	2.69 l (0.71 gal.) <sup>1</sup>
Max. Flow Rate.....	617 lpm (163 gpm)
Max. Size Solids.....	6.4 mm (1/4")

<sup>1</sup>Displacement per stroke was calculated at 4.8 bar (70 psig) air inlet pressure against a 2 bar (30 psig) head pressure.

**Example:** To pump 318 lpm (84 gpm) against a discharge pressure head of 2.1 bar (30 psig) requires 4.1 bar (60 psig) and 85 Nm<sup>3</sup>/h (50 scfm) air consumption. (See dot on chart.)

**Caution:** Do not exceed 8.6 bar (125 psig) air supply pressure.



Flow rates indicated on chart were determined by pumping water.

For optimum life and performance, pumps should be specified so that daily operation parameters will fall in the center of the pump performance curve.

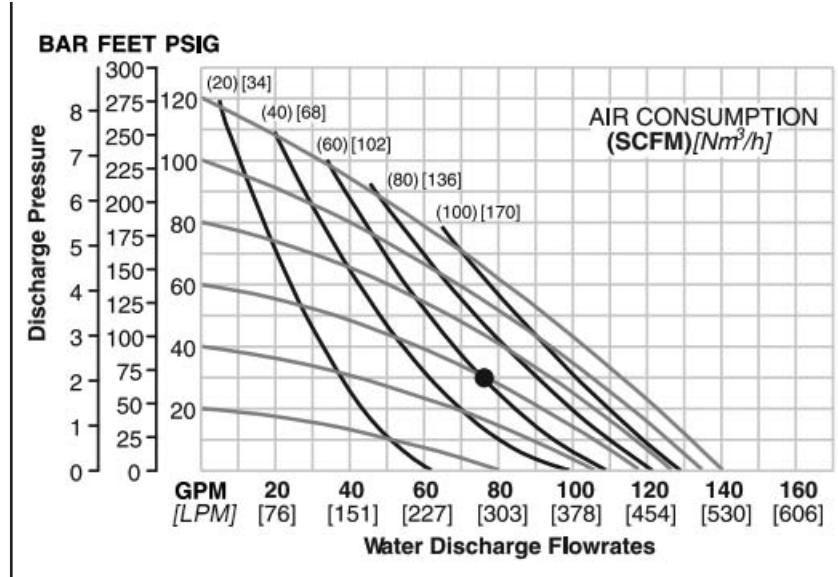
## PERFORMANCE NTG50 METAL PTFE-FITTED

Height.....668 mm (26.3")  
 Width.....404 mm (15.9")  
 Depth.....343 mm (13.5")  
 Est. Ship Weight.....Aluminum 33.1 kg (72 lbs)  
 316 S.S. 51 kg (112 lbs)  
 Air Inlet.....19 mm (3/4")  
 Inlet.....51 mm (2")  
 Outlet.....51 mm (2")  
 Suction Lift.....3.7 m Dry (12')  
 9.5 m Wet (31')  
 Displacement/Stroke.....1.51 l (0.40 gal.)<sup>1</sup>  
 Max. Flow Rate.....534 lpm (141 gpm)  
 Max. Size Solids.....6.4 mm (1/4")

<sup>1</sup>Displacement per stroke was calculated at 4.8 bar (70 psig) air inlet pressure against a 2 bar (30 psig) head pressure.

**Example:** To pump 284 lpm (75 gpm) against a discharge pressure head of 2.1 bar (30 psig) requires 4.1 bar (60 psig) and 102 Nm<sup>3</sup>/h (60 scfm) air consumption. (See dot on chart.)

**Caution:** Do not exceed 8.6 bar (125 psig) air supply pressure.



Flow rates indicated on chart were determined by pumping water.

For optimum life and performance, pumps should be specified so that daily operation parameters will fall in the center of the pump performance curve.

## SUGGESTED INSTALLATION

The suction pipe size should be at least 51 mm (2") diameter or larger if highly viscous material is being pumped. The suction hose must be non-collapsible, reinforced type as the NTG50 is capable of pulling a high vacuum. Discharge piping should be at least 51 mm (2"); larger diameter can be used to reduce friction losses. It is critical that all fittings and connections are airtight or a reduction or loss of pump suction capability will result.

Every pump location should have an air line large enough to supply the volume of air necessary to achieve the desired pumping rate.

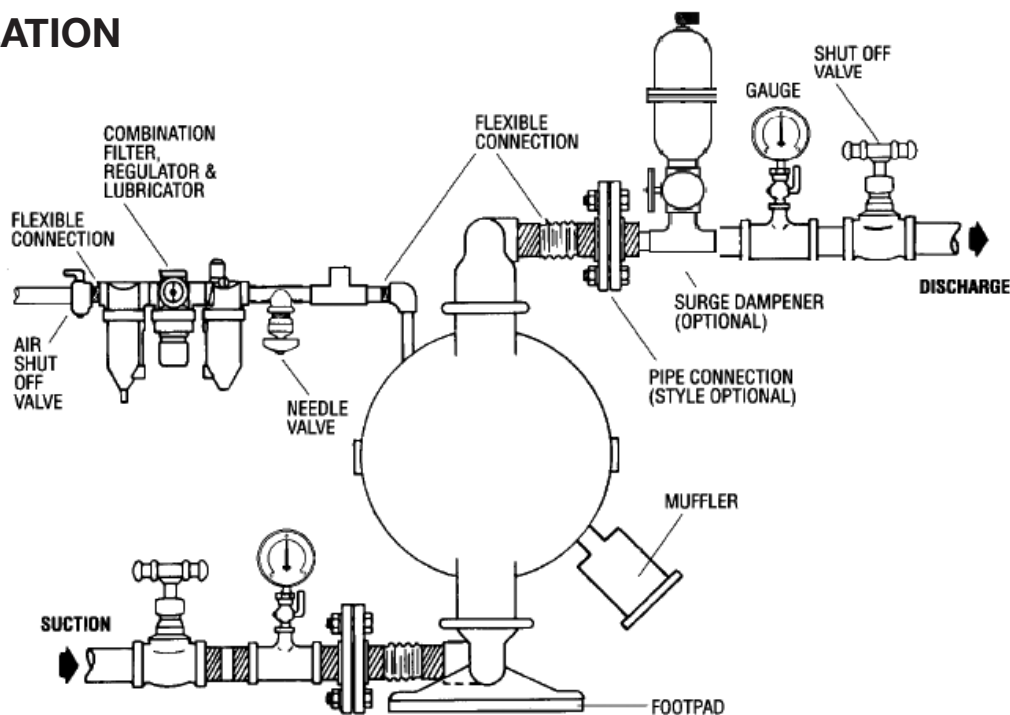
Unnecessary elbows, bends and fittings should be avoided. Pipe sizes should be selected so as to keep friction losses within practical limits. All piping should be supported independently of the pump.

Expansion joints can be installed to aid in absorbing the forces created by the natural reciprocating action of the pump. Flexible connections between the pump and rigid piping will also assist in minimizing pump vibration. A surge suppressor should be installed to protect the pump, piping and gauges from surges and water hammer.

When pumps are installed in applications involving flooded suction or suction head pressures, a gate valve should be installed in the suction line to permit closing of the line for pump service.

The NTG50 can be used in submersible applications only when both wetted and non-wetted portions are compatible with the material being pumped. If the pump is to be used in a submersible application, a hose should be attached to the pump's air exhaust and the exhaust air piped above the liquid level.

## SUGGESTED INSTALLATION



Note: In the event of a power failure, the shutoff valve should be closed, if the restarting of the pump is not desirable once power is regained.

## TROUBLESHOOTING

### ***Pump will not run or runs slowly.***

1. Check air inlet screen and air filter for debris.
2. Check for sticking air valve, flush air valve in solvent.
3. Check for worn out air valve. If piston face in air valve is shiny instead of dull, air valve is worn beyond working tolerances and must be replaced.
4. Check center block rings. If worn excessively, they will not seal and air will simply flow through pump and out air exhaust.
5. Check type of lubricant being used. ISO 15-5 wt. recommended.

### ***Pump runs but little or no product flows.***

1. Check for pump cavitation; slow pump speed down to match thickness of material being pumped.
2. Check for sticking ball valves. If material being pumped is not compatible with pump elastomers, swelling may occur.
3. Make sure all suction connections are air tight.

### ***Pump air valve freezes.***

Check for excessive moisture in compressed air.

### ***Air bubbles in pump discharge.***

1. Check for ruptured diaphragm.
2. Check for tightness for clamp bands, especially at intake manifold.

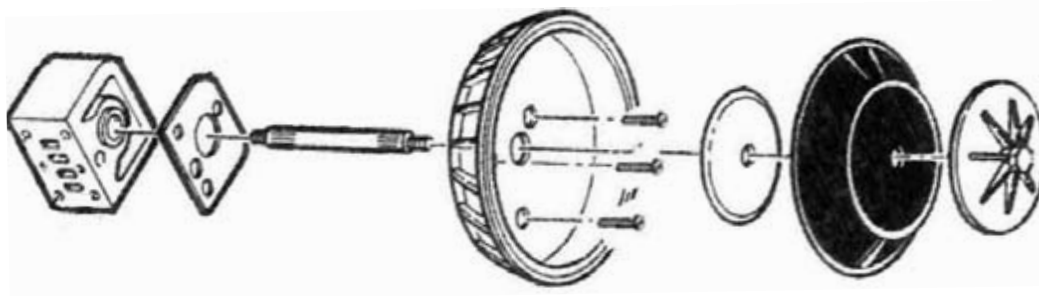
### ***Product comes out air exhaust.***

1. Check for diaphragm rupture.
2. Check tightness of piston plates to shaft.

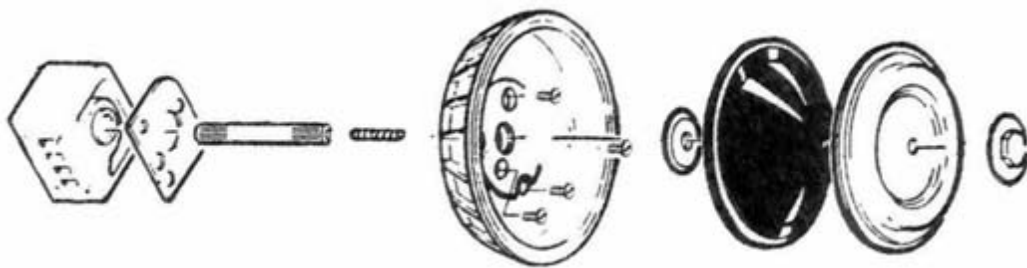
### ***Pump rattles.***

Create false discharge head or suction lift.

**EXPLODED VIEW (RUBBER DIAPHRAGMS)**



**EXPLODED VIEW (PTFE DIAPHRAGMS)**





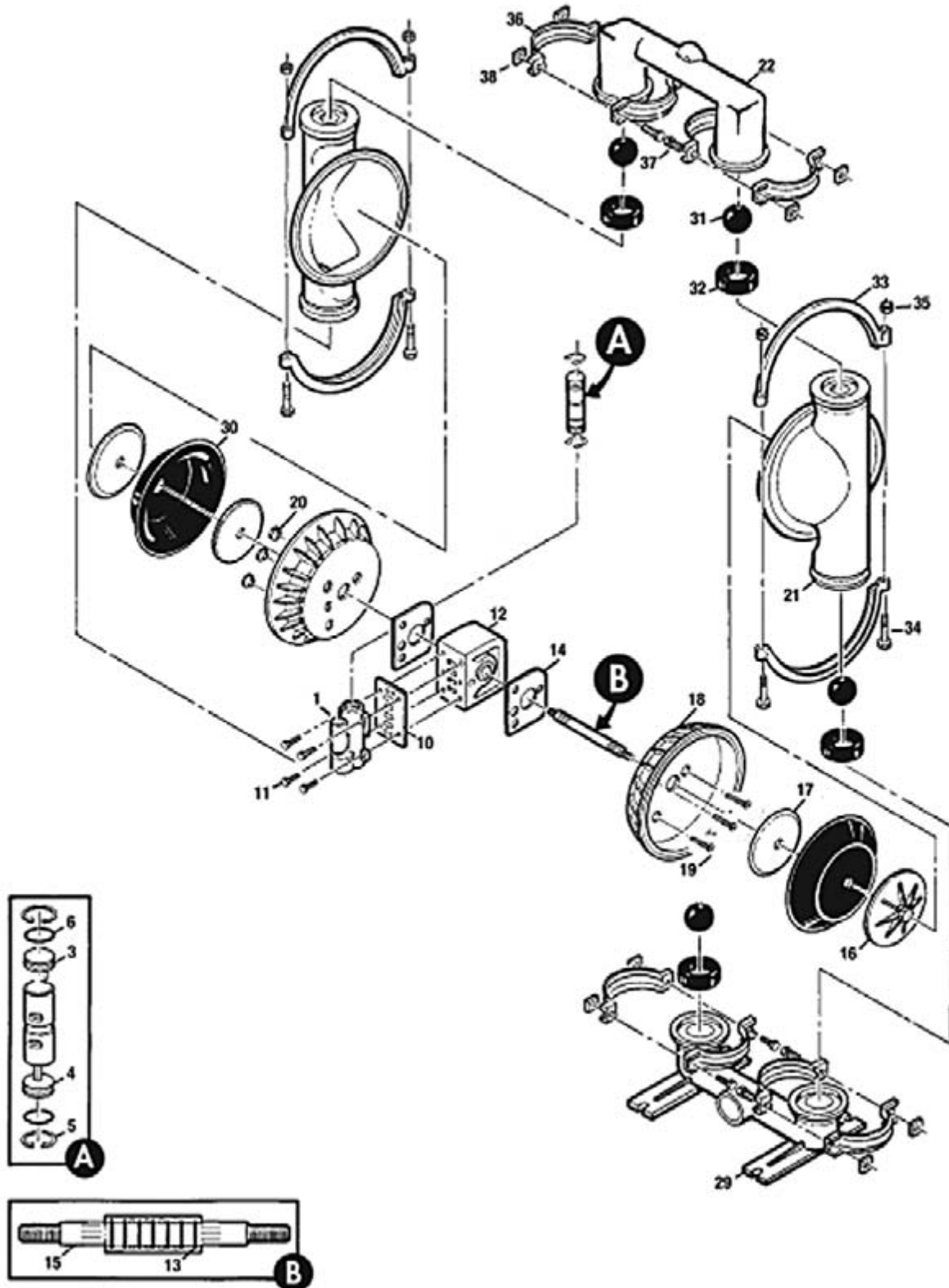
## NTG50 RUBBER-FITTED

Item	Description	Qty.	Part Number
1	Air Valve Assembly	1	N08-2012-07
3	Air Valve End Cap w/ Guide	1	N08-2332-01
4	Pressure Differential Cap	1	N08-2301-01
5	Air Valve Snap Ring	2	N08-2651-01
6	Air Valve Cap O-ring	2	N08-3201-52
10	Air Valve Gasket	1	N08-2600-52
11	Air Valve Screw 5/16" - 18 x 2 1/4"	4	N08-6000-08
12	Center Block	1	N08-3100-01-225
13	Center Block TRACKER™ Seal	7	N08-3210-77-225
14	Block Gasket	2	N08-3520-52
15	Shaft	1	N08-3800-03-07
16	Outer Piston	2	N08-4550-01
17	Inner Piston	2	N08-3700-01
18	Air Chamber	2	N08-3650-01
19	Air Chamber Screw 3/8" - 16 x 4"	3	N08-6200-08
20	Air Chamber Cone Nut 3/8" - 16	3	N08-6550-08
21	Liquid Chamber	2	N08-5000-01
22	Discharge Manifold	1	N08-5021-01
29	Inlet Manifold	1	N08-5080-01
30	Diaphragm - Neoprene	2	N08-1010-51
31	Valve Ball - Neoprene	4	N08-1080-51
32	Valve Seat - Neoprene	4	N08-1120-51
33	Large Clamp Band Assembly	2	N08-7300-08
34	Large Carriage Bolt 3/8" - 16 x 3"	4	N08-6120-08
35	Large Hex Nut 3/8" - 16	4	N08-6420-08
36	Small Clamp Band Assembly	4	N08-7100-08
37	Small Carriage Bolt 5/16" - 18 x 1-3/8"	8	N08-6050-08
38	Small Hex Nut 5/16"-18	8	N08-6450-08
	Muffler (Not Shown)	1	N08-3510-99

## NTG50 RUBBER-FITTED 316 S.S.

16	Outer Piston	2	N08-4550-03
21	Liquid Chamber	2	N08-5000-03
22	Manifold	1	N08-5021-03
29	Inlet Manifold	1	N08-5080-03
33	Large Lamp Band Assembly	2	N08-7300-03
34	Large Carriage Bolt 3/18" - 16 x 3/8"	4	N08-6120-03
35	Large Hex Head Nut 3/8" - 16	4	N08-6420-03
36	Small Clamp Band Assembly	4	N08-7100-03
37	Small Carriage Bolt 5/16" - 18 x 1-3/8"	8	N08-6050-03
38	Small Hex Head Nut 5/16" - 18 x 1-3/8"	8	N08-6450-03

## NTG50 RUBBER-FITTED



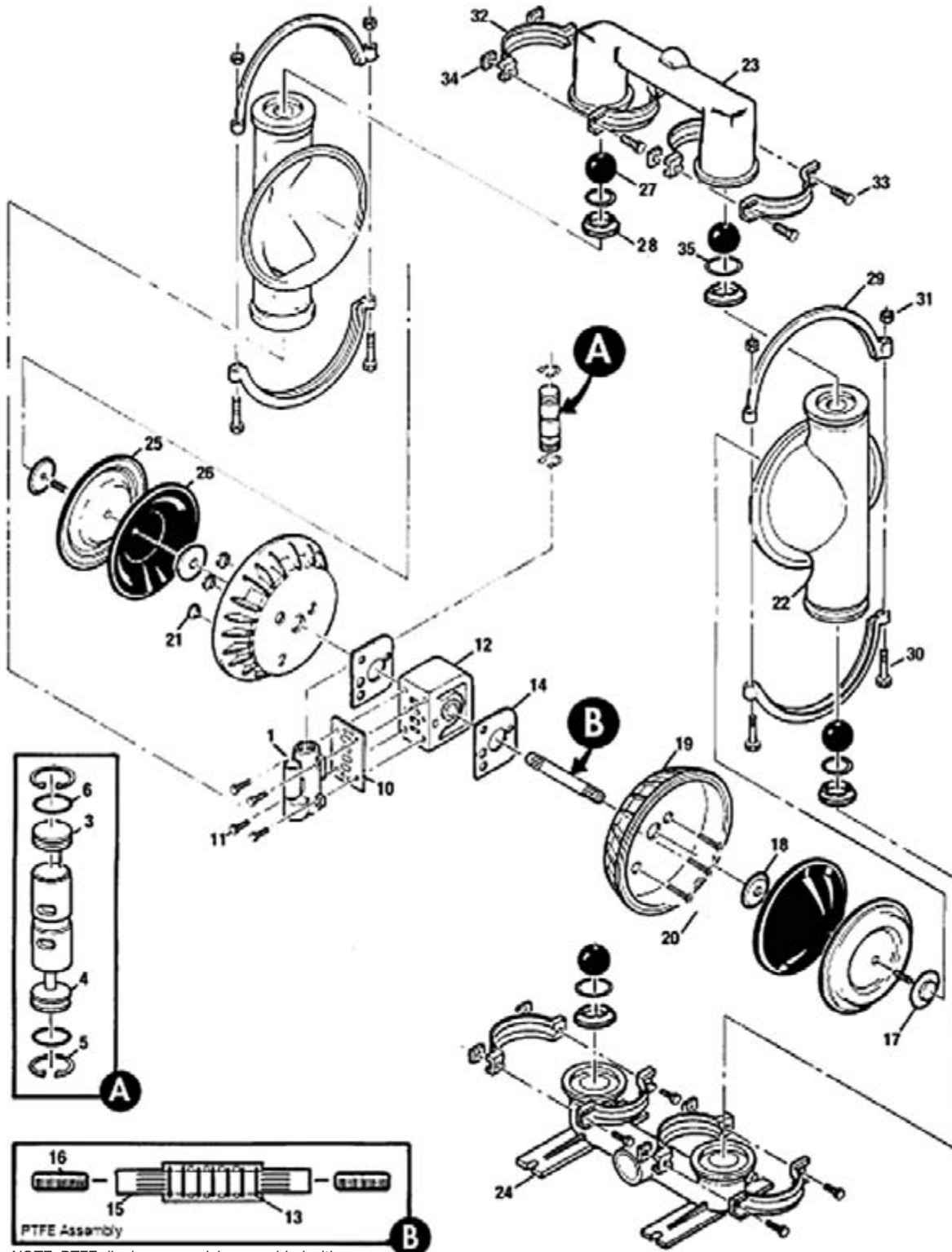
## NTG50 PTFE-FITTED

Item	Description	Qty.	Part Number
1	Air Valve Assembly	1	N08-2012-07
3	Air Valve End Cap w/ Guide	1	N08-2332-01
4	Pressure Differential Pump	1	N08-2301-01
5	Air Valve Snap Ring	2	N08-2651-01
6	Air Valve Cap O-ring	2	N08-3201-52
10	Air Valve Gasket	1	N08-2600-52
11	Air Valve Cap Screw 5/16" - 18 x 2 1/4"	4	N08-6000-08
12	Center Block	1	N08-3100-01-225
13	Center Block TRACKER™ Seal	7	N08-3210-77-225
14	Block Gasket	2	N08-3520-52
15	Shaft	1	N08-3820-03-07
16	Shaft Stud 1/2" - 20 x 1 - 7/8"	2	N08-6152-08
17	Outer Piston	2	N08-4600-01
18	Inner Piston	2	N08-3750-01
19	Air Chamber	2	N08-3650-01
20	Air Chamber Screw 3/8" - 16 x 3 - 9/16"	3	N08-6200-08
21	Air Chamber Cone Nut 3/8" - 16	3	N08-6550-08
22	Liquid Chamber	2	N08-5000-01
23	Discharge Manifold	1	N08-5021-01
24	Inlet Manifold	1	N08-5080-01
25	Diaphragm	2	N08-1010-55
26	Back-up Diaphragm	2	N08-1060-51
27	Valve Ball	4	N08-1080-55
28	Valve Seat	4	N08-1121-01
29	Large Clamp Band Assembly	2	N08-7300-08
30	Large Carriage Bolt 1/2" - 13 x 3 1/2"	4	N08-6120-08
31	Large Hex Nut 1/2" -13	4	N08-6420-08
32	Small Clamp Band Assembly	4	N08-7100-08
33	Small Hex Head Cap Screw 5/16"-18 x 1-3/8"	8	N08-6050-08
34	Small Hex Nut 5/16" -18	8	N08-6400-08
35	PTFE Valve Seat O-Ring	4	N08-1200-55
	Muffler (Not Shown)	1	N08-3510-99

## NTG50 RUBBER-FITTED 316 S.S.

11	Air Valve Cap Screw 5/16" - 18 x 2-1/4"	4	N08-6000-03
17	Outer Piston	2	N08-4600-03
22	Liquid Chamber	2	N08-5000-03
23	Discharge Manifold	1	N08-5021-03
24	Inlet Manifold	1	N08-5080-03
28	Valve Seat	4	N08-1121-03
29	Large Clamp Band Assembly	2	N08-7300-03
30	Large Carriage Bolt 1/2" - 13 x 3-1/2"	4	N08-6120-03
31	Large Hex Nut 1/2" - 13	4	N08-6420-03
32	Small Clamp Band Assembly	4	N08-7100-03
33	Small Clamp Hex Cap Screw 5/16" - 18 x 1-3/8"	8	N08-6050-03
34	Small Hex Nut 5/16" - 18	8	N08-6400-03

## NTG50 PTFE-FITTED



NOTE: PTFE diaphragm models assembled with PTFE gasket kit at factory (not shown).



A JDA Global Company

1351 Park Ave., Suite 104  
Redlands, CA USA 92373  
(909) 798-9532

N  M A D <sup>TM</sup>



NO BOUNDARIES <sup>TM</sup>